

▶ ELECTRONIC LOCKING SYSTEM

ELECTRONIC ROTARY LATCH

3331

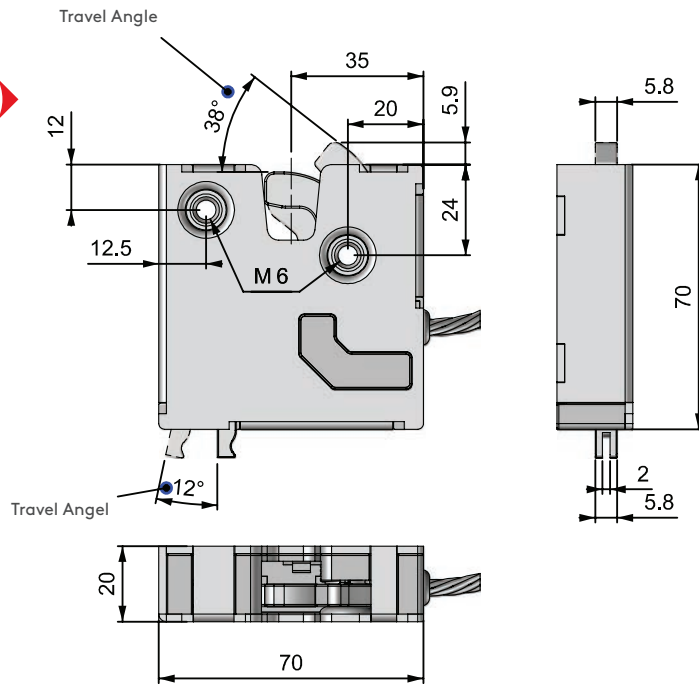

- Push to Close
- Mechanical override
- Stainless steel cam and trigger
- Integrated microswitch for lock status
- Microprocessor controlled gear motor
- Compatible with access control systems

MATERIALS

BODY: Steel and PA6 GFR 30
CAM: Stainless Steel

TECHNICAL SPECIFICATIONS

Operating Voltage : 9 - 24 Volt
Cable Length : 150 mm
Current : Max 500 MA

PIN	Color	Value
Pin 1	Black	GND
Pin 2	Green	12 Volt CD
Pin 3	Orange	Signal
Pin 4	Red	Microswitch COM
Pin 5	Blue	Microswitch NO
Pin 6	Brown	Microswitch NC

